

RVtechnicTM

RS20

User Manual &
Installation Guide

Automatic Start-Battery Isolator for 12volt RVs (Voltage Sensitive Relay)

With **Volt Meter, Water Tank Meters, Battery Alarms**

- Isolates start-battery automatically from house appliances when engine is off so no more flat start-batteries
- Charges house-battery automatically while driving
- Water tank meter for 3 tanks including grey water
- Battery voltage meter
- Alarms for house-battery voltage too low / high



- Proudly
Designed and
Manufactured in
New Zealand
- 2 Year Warranty

Thank you for purchasing an RVtechnic RS20 Automatic Start-Battery Isolator. We trust the product will provide excellent convenience, functionality and reliability for your motorhome or marine vessel.

1. Functionality and Features of the RS20:

- Automatically disconnects start-battery from house-battery when RV engine shuts off (avoids flattening start-batteries when running appliances while parked)
- Automatically connects house-battery to alternator when driving to charge house-battery
- Alarms when house-battery is too low or too high (under 11.8V, over 15.0V). Peace of mind when drawing power from or charging your expensive house-batteries
- Monitors up to 3 water tanks including grey water (tank sensor cables to be purchased separately)
- Simple to integrate with solar panels
- Automatically reduces charge rate if house-battery is over charging (if house-battery exceeds 15.1V)

Important :

- Please read this guide in full prior to installation and use
- Installation must be carried out in direct accordance with this guide.
- To avoid risk of serious damage, fuses must be replaced with correct fuse type and rating (refer to Trouble Shooting Guide in this manual).

2. Front Panel Functions

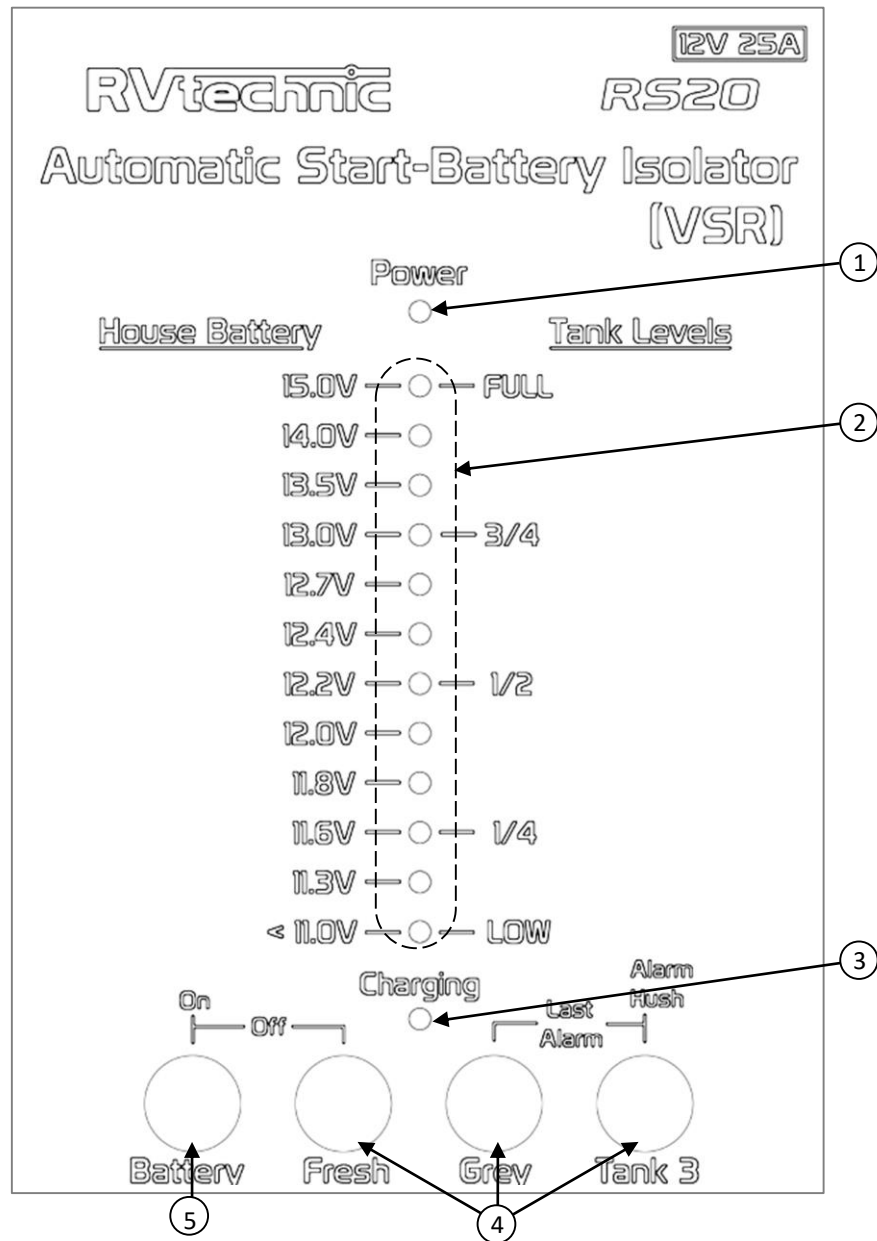

Key:

- 1) **Power** LED flashes once per minute when RS20 is on
 - 2) Indicator LEDs for voltage or tank levels (voltage displays as a single LED when buttons not pressed)
 - 3) **Charging** LED is on when house-battery is charging from engine alternator
 - 4) Push buttons to indicate water tank levels
 - 5) Push button to indicate house-battery voltage (as a row of LEDs)
- Press **Battery** and **Fresh** buttons together to turn off the unit
 - Press **Battery** button to turn the unit on from off-state
 - Press **Tank 3** button to hush repeating alarm sounds
 - Press **Grey** and **Tank 3** buttons together to display the most recent alarm code

3. Installation

- Connect cables to RS20 **before** connecting cables to batteries – to reduce risk of damage from energised wires either shorting together or contacting RS20 circuit board during install.
- Installation should be performed by a person familiar with wiring DC electrical equipment. If unfamiliar, please use an automotive electrician or similarly qualified person.

RS20 Connections in a 12volt RV

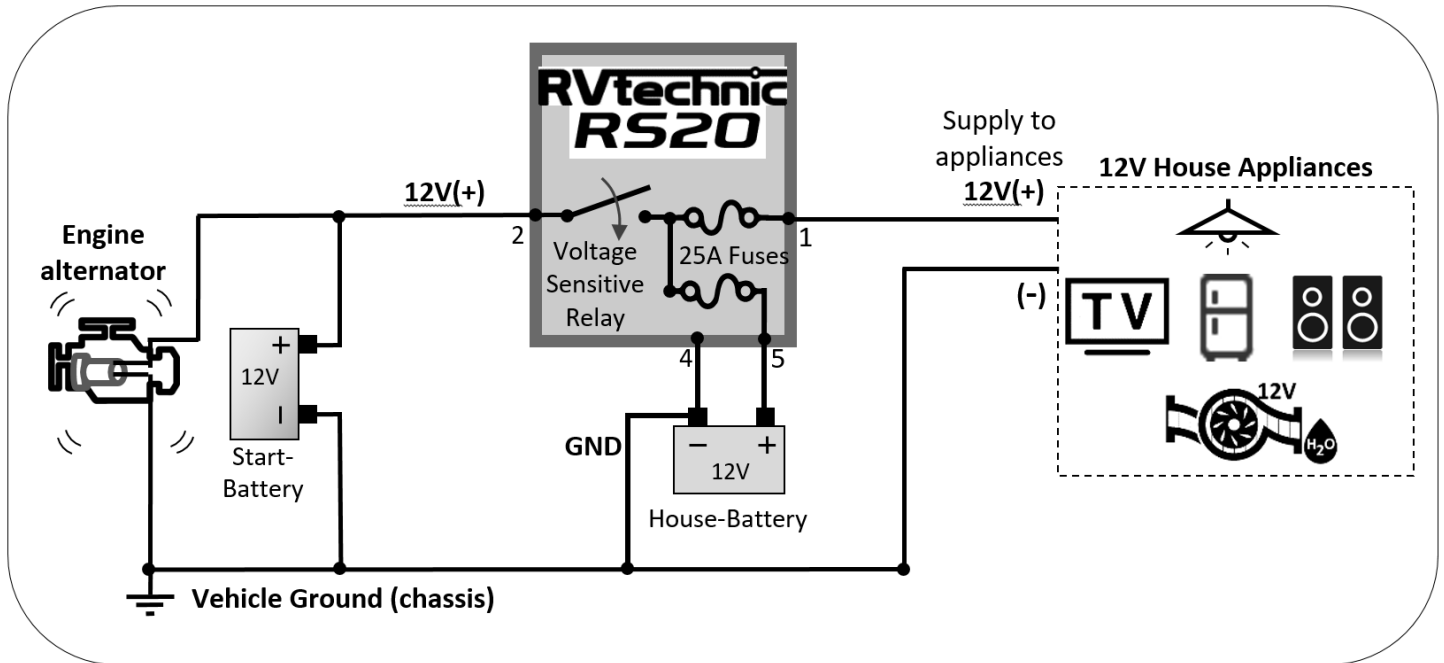

Connecting Solar / 12V Charger to RS20 For Charging House-Battery

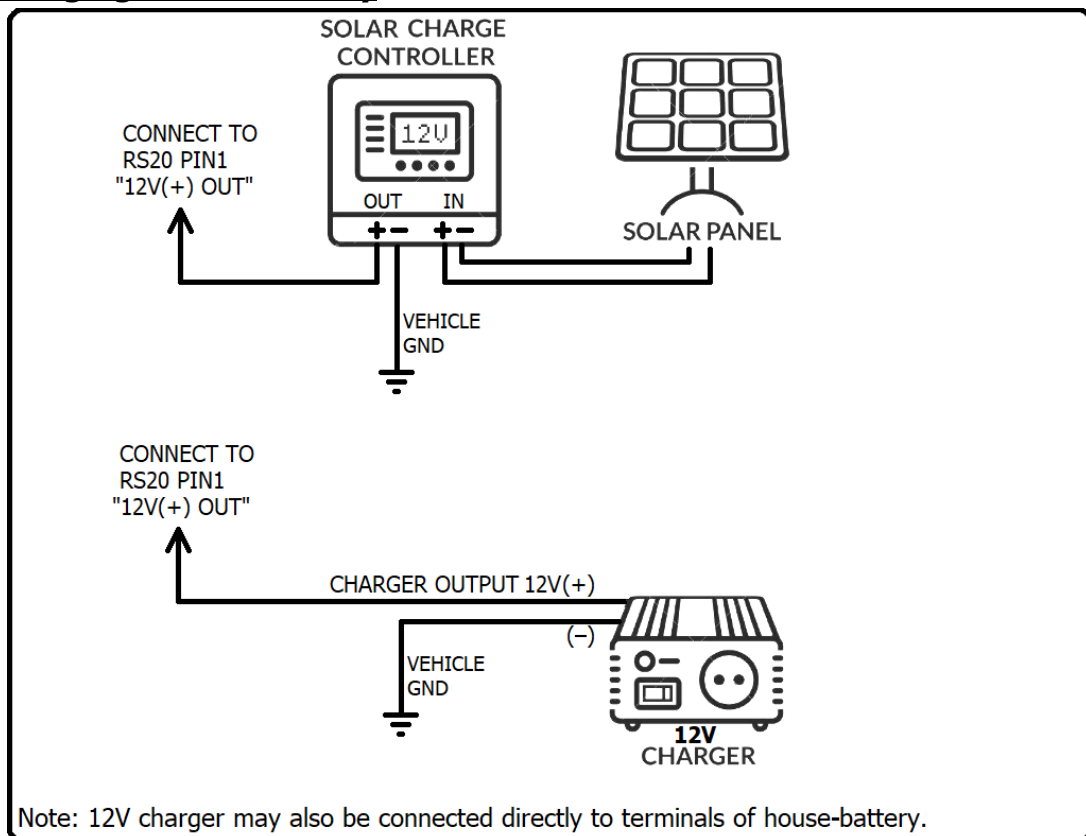

Wall mounting

1. Separate front from rear case (pull apart)

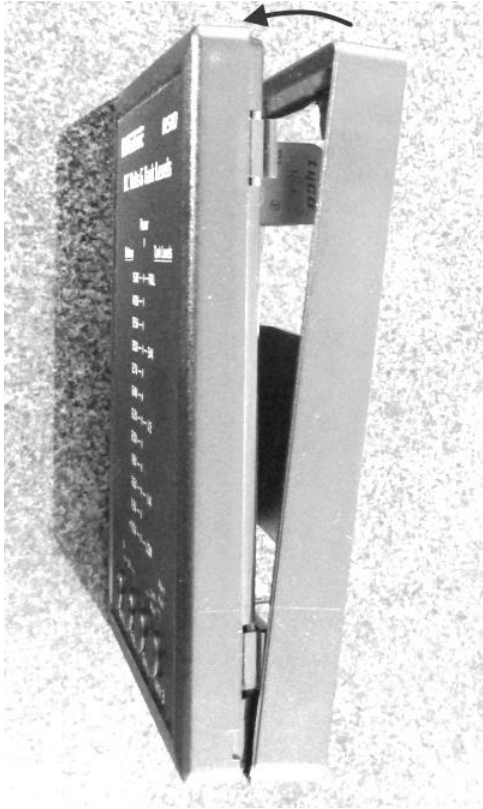

2. Using rear case as a guide, cut out wall panel sections to enable cable access.

3. Screw rear case onto wall using enclosed screws

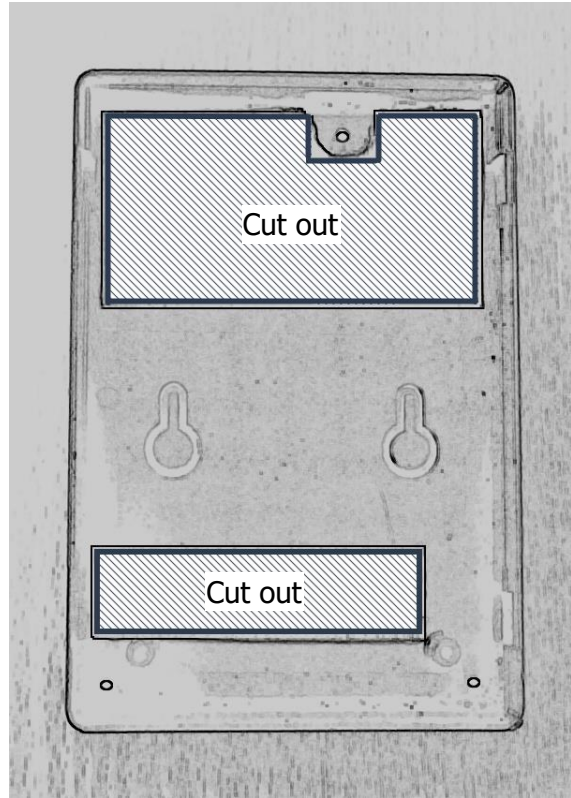

Installation Notes:

1) House-Battery Sizing:

- 12volt flooded lead-acid, SLA or AGM batteries (deep-cycle or standard) can be used
- Maximum 800CCA (cold cranking amps) for house-battery is recommended to avoid high charging currents that may blow RS20 fuse (25Amp ATO type fuse). Higher CCA rated battery may be used if the 12V(+) wire from start-battery to RS20 is >4m long and <5.5mm² conductor size (AWG10 or smaller).

2) Cable Sizing:

Recommended AWG12 to AWG10 (3.3mm² to 5.3mm² conductor) for RS20 rear connections: 1,2,4,5 - See figure below. Use 5.3mm² or larger for long cable runs. For connection3 (optional IGN/ENG RUN signal) light wire gauge can be used.

3) Connection3 (optional IGN/ENG RUN signal):

This may be connected to a 12V IGN signal switched by the ignition key (zero volts when key is off) to quicken RS20 automatic switching in/out of **Charging** mode.

If connected to IGN signal, the RS20 will switch in/out of **Charging** mode soon after engine is started/stopped. If left disconnected, the RS20 will automatically switch in/out of **Charging** mode by sensing start-battery voltage.

RS20 Rear Connections

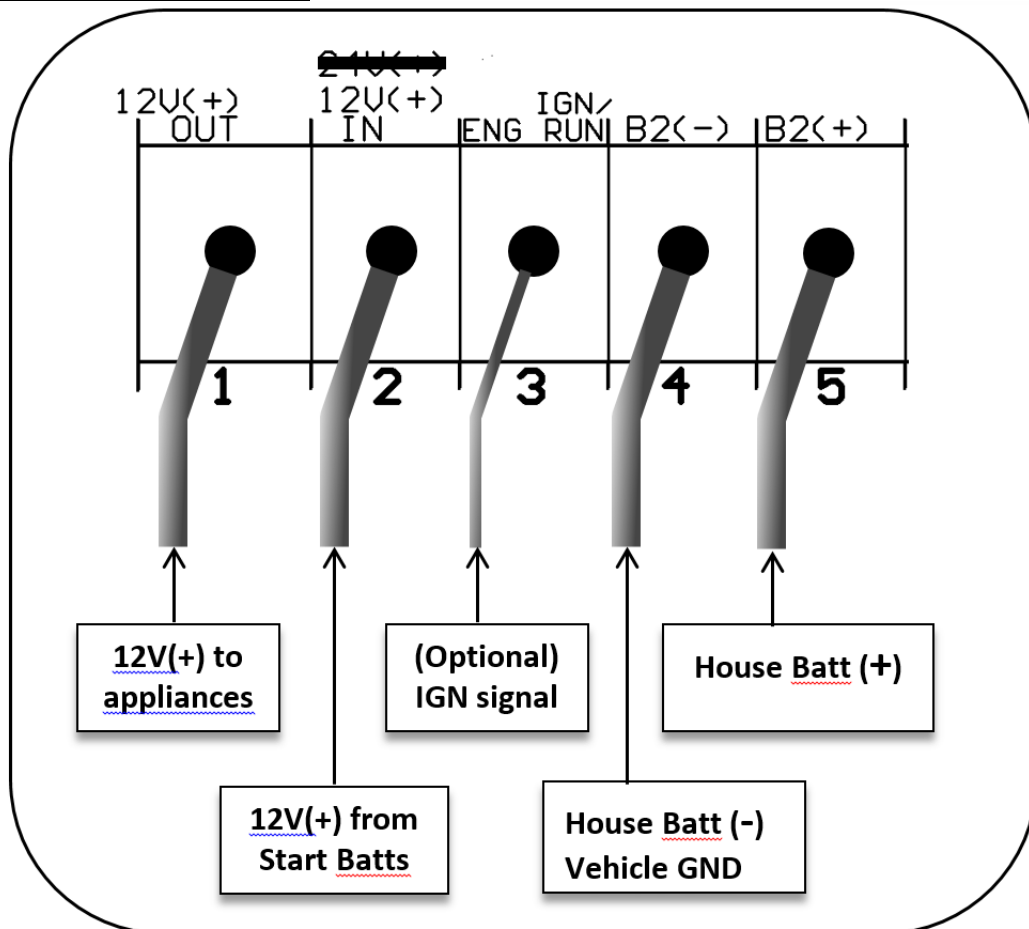

4. Alarms

Note: Alarm sound is two short, low tones

While not in Charging mode (RV engine not running):

House-battery voltage	Alarm
Over 15.1V (over-charging from solar or other source)	All batt LEDs flash every 3 secs indicating high batt voltage. Alarm sounds once per minute
11.8V to 11.9V	Batt LEDs flash every 3 secs indicating house-battery voltage. No alarm sound
11.5V to 11.8V	Batt LEDs flash every 3 secs indicating house-battery voltage. Alarm sounds once per minute
Below 11.5V	Batt LEDs flash every 1 sec indicating house-battery voltage. Alarm sounds once every 10 secs

While in Charging mode (RV engine is running):

House-battery voltage	Alarm
House-battery over 15.1V (over-charging from alternator)	Batt LEDs flash every 1 sec indicating high batt voltage. Alarm sounds once every 10 secs. RS20 automatically switches out of charging mode after 1 minute of this condition

Other alarms:

Condition	Alarm
Fresh tank level drops below 1/4 tank	Single short beep alert. No LEDs flash

5. User Settings

To switch off all sounds including alarm tones:

Hold **Battery** and **Tank3** buttons for 5 seconds and release (then USER settings mode will be active for 3 seconds and power LED will flash). While flashing, Press **Grey** button (sounds status will change from ON to OFF).

Repeat this process to change sounds status from OFF back to ON.

To switch off single LED voltage display:

(By default a single LED always displays to indicate house-battery voltage while no buttons are pressed. The following process will switch single LED voltage display on/off)

Hold **Battery** and **Tank3** buttons for 5 seconds and release (then USER settings mode will be active for 3 seconds and power LED will flash). While flashing, Press **Fresh** button (single LED display mode will change from ON to OFF).

Repeat this process to change single LED display mode from OFF back to ON.

Extra voltage-display function:

Press **Battery** and **Grey** buttons together, LEDs indicate 12V input voltage (start-battery voltage).

6. Trouble Shooting Guide

Problem	Possible cause(s)	Solution(s)
<p><u>While RV engine is not running:</u> Voltage display LEDs flash and alarm sounds</p> <p><i>Note1: 12V lead-acid, SLA and AGM batteries can be degraded or damaged if voltage is kept below 12V or above 15V for long periods.</i></p>	<p>House-battery voltage is too low or high (refer to Alarms section)</p> <p><i>Note2: 3-way or 2-way fridges (running on 12V supply) draw 10 to 15 Amps and will flatten house-battery quickly without engine running.</i></p>	<p>If flashing display LEDs are indicating 11.8V or lower, house-battery voltage is low. It is recommended that loads are switched off and battery charged.</p> <p>If all voltage display LEDs are flashing, house-battery voltage has been over 15.1V for more than 1 minute which can damage 12V batteries. Remove charging source.</p>
<p><u>While RV engine is running:</u> RS20 switches in then out of charging mode (Charging LED on for a few seconds then off for a few seconds repeatedly).</p> <p><i>Note: RS20 sounds a short beep each time it goes into charging mode</i></p>	<p>House-battery is heavily discharged causing start-battery voltage to dip when RS20 goes into charging mode.</p>	<p>Connect IGN signal to RS20 connection3 (see Installation Notes in this manual)</p> <p>Or charge house-battery (using mains battery-charger / solar etc) prior to starting RV engine.</p> <p>Or turn off RS20 (using Battery+Fresh buttons), run RV engine for 5 minutes at over 900rpm to charge start-battery, turn on RS20, keep running RV engine at over 900rpm until RS20 successfully stays in charging mode (Charging LED on)</p>
<p>RS20 fuses blow frequently</p>	<p>House-battery CCA (Cold Cranking Amps) rating is too high and the high charge current exceeds fuse rating</p>	<p>Change house-battery to lower CCA rating. Recommended for RS20: 800CCA or lower for house-battery</p>
	<p>12V appliance loads exceed fuse rating</p>	<p>Reduce appliance loads</p>
	<p>Spanner handle or other tool is shorting to vehicle chassis while making/removing battery connections</p>	<p>Avoid shorting tools to vehicle chassis, use insulated tools during installation/removal of RS20 and batteries</p>
<p>All voltage display LEDs flash and alarm sounds while RV engine is running and Charging LED is on</p>	<p>Engine alternator output voltage exceeds 15.1V</p>	<p>Repair or replace alternator</p> <p><i>Note: To protect house-battery the RS20 automatically switches out of charging mode after 1 minute of this over-voltage condition</i></p>
<p>Grey water meter reading low when water is present in the tank</p>	<p>Grey water is particularly clean</p>	<p>Add ½ teaspoon of salt into grey tank (wash salt down sink/basin/shower drain).</p> <p><i>Note: Grey water meter sensitivity is set low to avoid false-reads from dirty/fouled tank sensors</i></p>
<p>Water meter(s) reading water is present when tank(s) empty</p>	<p>Water tank sensors are particularly dirty/fouled</p>	<p>Remove tank sensors from side of tank, clean, reinstall.</p>

7. Electrical Specifications

Item	Specification
Recommended house-battery specifications	12volt flooded lead-acid, SLA or AGM battery (deep-cycle or standard) can be used. 2 x 6V batteries connected in series may also be used in place of 12V house-battery. <u>Amp hour (Ah) Capacity Recommendation:</u> Minimum 10Ah. Maximum 300Ah total (add Ah ratings together for paralleled batteries). <u>Cold Cranking Amps (CCA) Recommendation:</u> Maximum 800CCA total (add CCA ratings together for paralleled batteries). Higher CCA rated batteries may be used if the 12V(+) wire from start-battery to RS20 is >4m long and <5.5mm ² conductor size (AWG10 or smaller). See Installation Notes in Installation section for additional information.
RS20 current consumption (while active and off-charge)	4mA
Charging Efficiency @ avg 5A charge	98%
Charging Efficiency @ avg 10A charge	97%
"12V" RV alternator output voltage when running	13.7V to 14.5V (required for charging house-battery via RS20 unit)
RS20 connection3 input voltage	11V to 15V (for IGN-on status) < 3V (for IGN-off status)
RS20 connection3 input current	< 0.5mA (with IGN signal on)
12V(+) max input current from start-battery / alternator	Max 35A for up to 10 seconds
Fuse rating (Batt2+ and 12V_OUT on RS20 rear side)	25Amp automotive ATO type. To avoid risk of serious damage, fuses must be replaced with correct fuse type and rating

Conditions enabling switching in/out of Charging mode:

Note: "IGN input" means connection3 of RS20 rear connections

IGN input "High" status requires 11V to 15V. IGN input "Low" status requires below 3V

	IGN input	12V(+) IN	Notes
Switch into Charging mode when	Either: High	> 12.75V	
	Or: Low (not used)	> 13.6V	
Switch out of Charging mode when [if IGN input was High when going on-charge]	Either: was High, now Low	n/a	Goes off-charge irrespective of battery voltage
	Or: High	< 12.5V	
	Or: Low (not used)	< 12.95V	

8. Warranty Information

Before calling for service or assistance please carefully check the Troubleshooting Guide and Installation information contained in this document.

1. In this warranty:
 - (a) "RVtechnic" means RVtechnic Ltd NZBN: 9429030541535;
 - (b) "you" means the purchaser of the Product not having purchased the Product for re-sale, and "your" has a corresponding meaning;
 - (c) "Product" means the RVtechnic product purchased by you accompanied by this document;
2. RVtechnic issues this limited warranty to the original purchaser of this product. This limited warranty is not transferable. The warranty applies to manufacturing faults and material defects for 2 years from the date of purchase. The purchaser must return the product for inspection together with the receipt of purchase to either the retailer if purchased from a retail outlet, or to RVtechnic.
3. RVtechnic is not liable in the following situations (which are not exhaustive):
 - (a) the Product is damaged by:
 - (i) accident
 - (ii) misuse or abuse
 - (iii) normal wear and tear
 - (iv) incorrect power supply
 - (v) incomplete or improper installation
 - (vi) incorrect, improper or inappropriate use, application or operation
 - (vii) insect or vermin infestation
 - (viii) failure to comply with any additional instructions supplied with the product;
 - (b) the Product is modified without authority from RVtechnic in writing;
 - (c) the Product's serial number or warranty seal has been removed or defaced;
 - (d) the Product was serviced or repaired by anyone other than RVtechnic or an RVtechnic authorised repairer.
4. RVtechnic will, at its sole discretion, either (i) return the Product to you if it is not determined to be defective, or (ii) without regard to whether or not the original Product is determined to be defective, either (A) provide you with a replacement product of the same or comparable model, or (B) provide you with a refurbished or repaired Product
5. To the extent permitted by law: (a) RVtechnic excludes all warranties other than as contained in this document; (b) RVtechnic shall not be liable for any loss or damage whether direct or indirect or consequential arising from your purchase, use or non-use of the Product.

For service, please email: service@rvtechnic.co.nz

Or call (in NZ) 021-1542255, (outside of NZ) +64-21-1542255

For further contact details go to our website: www.rvtechnic.co.nz